



# Rules for playing **SENET**

Copyright 1946 by

*Parker Brothers Inc.*

SALEM, MASSACHUSETTS  
NEW YORK CHICAGO LONDON

The game SENET originated in Egypt four thousand years or more ago and was the favorite game of kings and their subjects, as shown by mural paintings and sculpture in excavations of ancient temples, tombs and relics. The painting on the box cover is thus described by the authorities of the Metropolitan Museum of Art:

"Sitting in a pavilion playing senet by the official in the Place of Truth (the cemetery at Thebes), Neb-maet, and his wife, the lady Mer-set-ger." Behind Neb-maet, is "his beloved daughter, Hu-en-ro." This painting appears on a wall of the tomb of Neb-maet at Thebes.

The exact rules for the game SENET as played in the days of the ancient Pharaohs are not now known, and various theories of its exact method of play have been expressed by widely differing authorities. As here presented the publishers wish to acknowledge assistance rendered by the famous Egyptologists, Dr. Ambrose Lansing of the Metropolitan Museum of Art and Dr. Carleton S. Coon. We also are indebted to Eliot D. Chapple, Ph.D. and Messrs. Milton E. Lord and Dows Dunham of Boston. As a result the method of play as herein developed has produced a game of provocative appeal and extraordinary interest.

## FOR TWO PLAYERS

### The Object:

THE OBJECT OF THE GAME IS TO CAPTURE ALL OF THE OPPOSING PEGS AND REMOVE THEM FROM THE BOARD, THEREBY WINNING THE GAME.

# EQUIPMENT

## The Pegs:

There are five PEGS all of the same color for each player. Four of these are "MEN," the fifth PEG (which is double-topped) being a PHARAOH possessing great power in play.

## The Board:

THE BOARD or playing field is divided into 3 rows of 10 spaces each. The middle row is the SENET ROW — the two outside rows are SAFETY ROWS where ALL pegs are safe from capture.

The Safety rows have one hole in each space while the SENET ROW spaces each have TWO holes, and are additionally marked with directional arrows.

At no time may a player's peg occupy a space in his opponent's path. (Keep on path of your own color.)

## The Paths:

The picture below shows the two separate paths and the direction in which the pegs travel, one path being used by the red pegs, the other by the opposing yellow pegs.

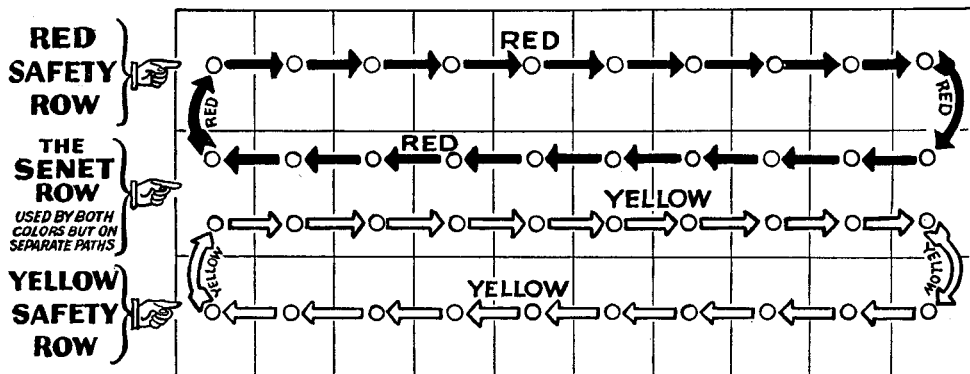

Note that each path is continuous.

During the game pegs sometimes make SEVERAL CIRCUITS around their own paths before the game is finished.

# THE PLAY

## Setting Up The Pegs:

Set pegs in starting positions as illustrated on front page.

Each player places his PHARAOH in the *illustrated corner* space on his side of the board which shows in white outline the face of a Pharaoh. The four men are placed in the four succeeding illustrated spaces in that row.

## Rolling The Dice:

Two DICE are provided for each player.

Roll the dice to determine the Starting Player. High moves first. Starting Player now rolls again and moves. (The throw of Doubles has no special significance.)

## Moving The Pegs:

A player after rolling his dice may choose to combine the count exposed on his dice and move one peg the total of both dice; or, he may move one peg for each die. The plain pegs or "men" may not move backward but must follow the direction of the arrows of their own color. No peg other than the Pharaoh may in moving pass over any other peg.

The Pharaoh, however, may in moving pass over any of the pegs of his own color counting any spaces already occupied by pegs as if such spaces were vacant, provided the throw of the dice permits him to reach an unoccupied space.

The Pharaoh when on the Senet Row, may move either forward or backward or even divide the throw by moving forward for the throw indicated by either one of the dice, and in the opposite direction for the other.

## Forfeiting a Move:

A player's move is forfeited if he cannot move a Peg the exact number of holes indicated by either one of his dice.

However, IF IT IS AT ALL POSSIBLE to make a move, it must be done, even if it means moving the Pharaoh into a dangerous position.

## Capturing:

Any peg (whether Pharaoh or man) can be CAPTURED if the opposing player's peg can reach, whether by the exact count of one of the dice or both the dice combined, a peghole in the Senet Row directly opposite an opposing Pharaoh or man. Movement of the Pharaoh or men to accomplish a CAPTURE is governed by the same movement rules described in "Moving the Pegs."

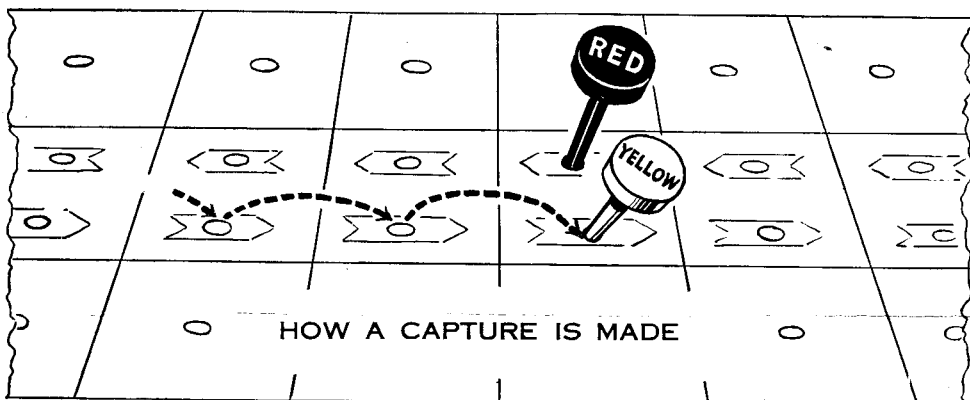

Yellow rolled  $\square \cdot \square$  and moves 3 spaces — reaching a space directly beside an opponent, thereby capturing it and removing it from the board. Yellow's turn now ends.

A plain peg or a Pharaoh are equally subject to capture by any opposing peg or Pharaoh if the dice throw allows.

## Strategy:

It is important to remember that captures can only be made IN THE SENET ROW. The shrewd player will probably move at least one or possibly two pegs out onto the Senet Row early in the game in the hope of capturing an opposing piece already in that Row. The Pharaoh is so valuable and powerful his moves and position are very important.

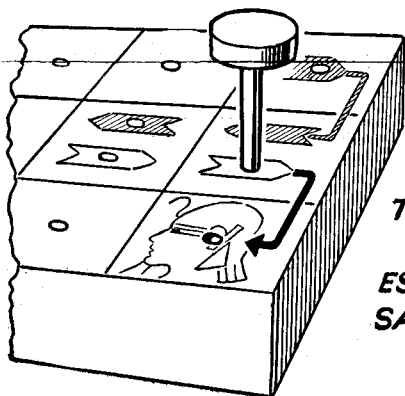

**A PEG  
WAITING  
FOR A  
"ONE"  
TO TURN UP.  
BEFORE  
ESCAPING TO  
SAFETY ROW  
BELOW**

## Waiting For a "One":

PLAIN pegs do not enjoy the privilege of moving from the Senet Row into the Safety Row in one move without stopping.

A plain peg, instead, must reach the LAST space in the Senet Row, directly above the picture of the Pharaoh, by exact count. For example, should you need 3 to reach this space and roll 4-6, you cannot play that peg, but should you throw 3-6, you may reach the space with the three and play the six elsewhere, if possible.

When a plain peg eventually reaches the last space it must wait there until a "one" turns up on either die BEFORE moving into the Safety Row, thus avoiding possible capture for awhile. Of course, the space immediately below must be UNOCCUPIED to receive it — otherwise, the count of the dice should be used to move other pegs.

*(The reason for this particularly interesting play will become apparent after a few games have been played.)*

**NOTE:** The above rule is optional. If the players prefer to waive the rule they must agree to do so BEFORE the game begins.

This means that any peg may move from the Senet Row down to its Safety Row IN ONE MOVE, and without stopping, providing of course that the roll of the dice permits.

## The Power of the Pharaoh:



The Pharaoh has many privileges and powers not enjoyed by the plain Pegs.

1. The Peg representing the Pharaoh may pass ANY PEG ANYWHERE on the path of his own color, counting in such a move any occupied spaces as if unoccupied.

2. The Pharaoh may move forward OR BACKWARD while on the Senet Row, but on the Safety Row forward only. His BACKWARD move must not carry him onto his Safety Row.

3. The Pharaoh may move forward on one die and then move backwards on the other die. He may NOT, however, split the count of EITHER die.

4. The Pharaoh is privileged to move, if dice throw allows, from the Senet Row to his own safety path in one turn WITHOUT WAITING for a  to turn up, as is the restriction on the ordinary pieces.

*\*When a player has lost his Pharaoh, and all of his pegs but one, that LONE Peg assumes all of the powers and privileges of the Pharaoh.*

### The Winner:

THE WINNER is the player who first captures and removes all of his opponent's pegs from the board. (A special scoring arrangement used in many locations is shown below.)

### Special Scoring:

Where a series of games is to be played and a count kept, many players desire to use the following scoring system.

The winner of each game has his score reckoned by the number of his own pieces left uncaptured on the board. A Pharaoh saved counts 25 points. Each plain peg counts 10 points. If a player has saved all his pieces double his score.

### PLEASE REMEMBER

### Notes:

A capture is made only when one peg comes to rest ALONGSIDE of an opposing peg in the Senet Row.

Plain Pegs must NOT pass another Peg of the SAME COLOR.

The Pharaoh may move forward AND BACKWARD while on the Senet Row, but only forward while on his SAFETY Row.

